

Single Track Lift Bridge

HO-Scale

NOTE: Sanding is recommended to remove support material.

CAUTION: Resin dust is harmful. Use protective gear while sanding.

*Assembly Required

*Due to the manufacturing process, supports will need to be removed.

*Wire or thread are NOT included

*Track is NOT included

Remove Supports

1) Remove the tower supports using the tip of a sharp pair of sprue cutters or a razor knife. These are shown as black in Figure 1

2) Remove bridge supports. These are shown as black in Figure 2 and Figure 3

3) Place in a UV chamber or direct sunlight for 5-15 minutes to finish the curing process. This will get rid of the sticky feeling on the models.

Figure 1

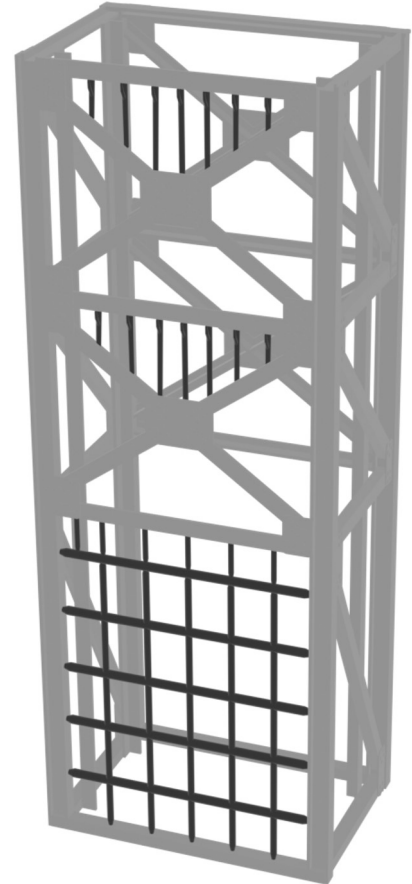

Figure 2

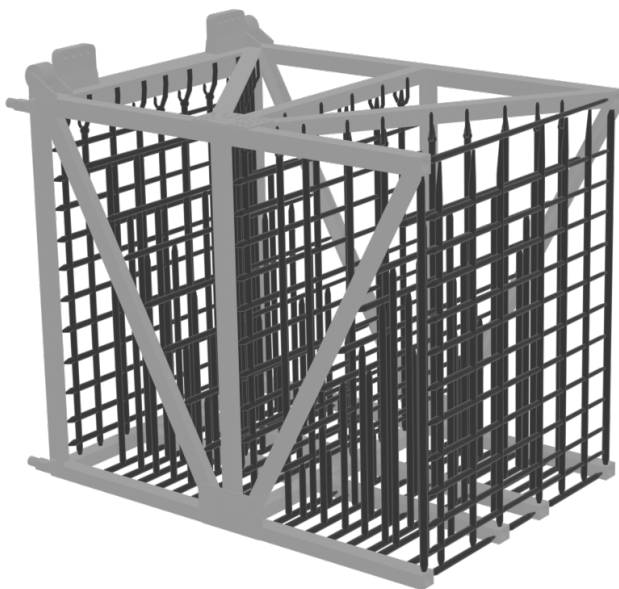
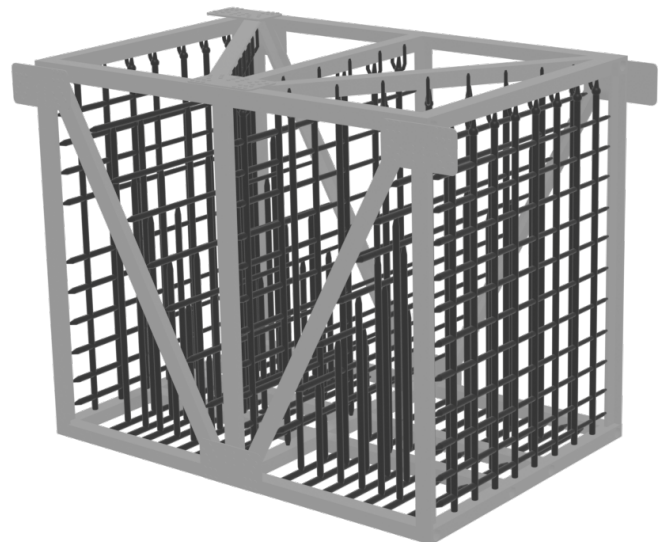

Figure 3



Single Track Lift Bridge

HO-Scale

Tower Assembly

- 1) Assemble the pulleys as shown in Figure 3.
- 2) Glue pulleys on the tower top as shown in Figure 4.

Figure 3

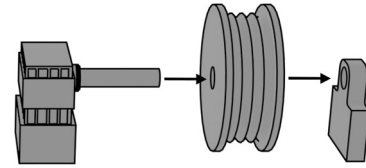
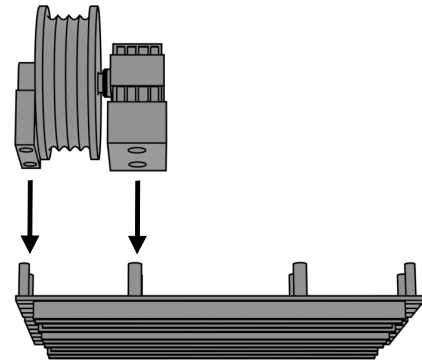

Figure 4



Bridge Assembly

- 1) Use 2.5mm or .098 inch wire (NOT included) to reinforce bridge pieces as shown in Figure 6 and glue all three pieces together.
- 2) Attach wires or thread (beading wire, or elastic thread is recommended) to bridge, tying or gluing them in place.

Figure 6

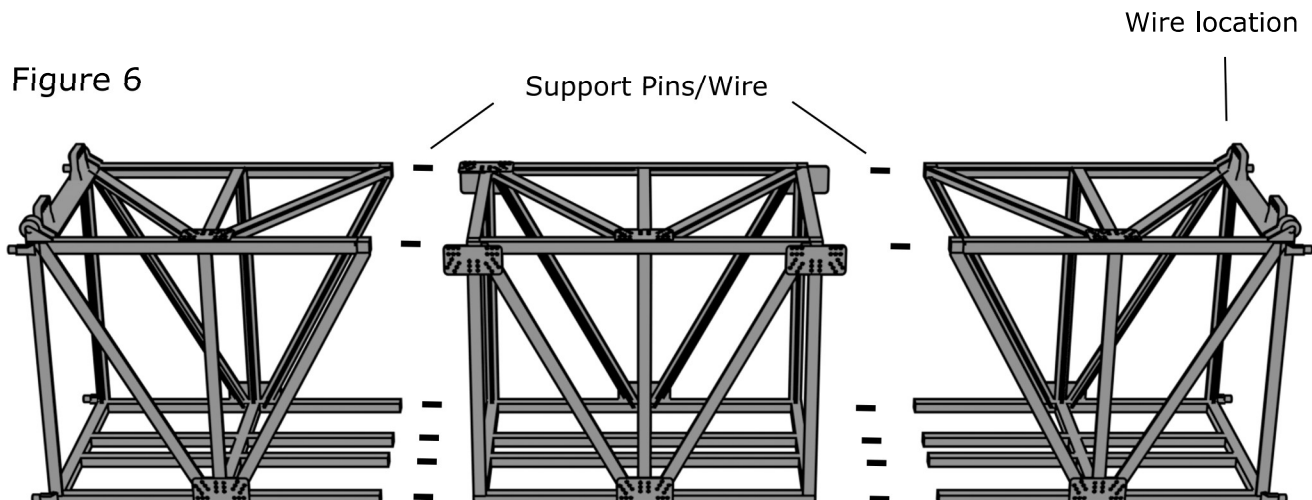

Single Track Lift Bridge

HO-Scale

Bridge Length

The length of the bridge can be adjusted by cutting sections off and using the included bolt panel detail pieces. These are not needed if you are using the full length of the bridge.

To shorten the bridge by one or two sections, cut as shown in Figure 8. New holes will need to be drilled in the base to attach pins for support.

The center piece of the bridge may be left out to shorten by two sections as well.

Overall, the bridge can be reduced by up to four (4) sections to accommodate nearly any desired length.

Cut here if you are going to be using the center piece.

Cut here, leaving the horizontal beam, on one piece if you are not using the middle piece.

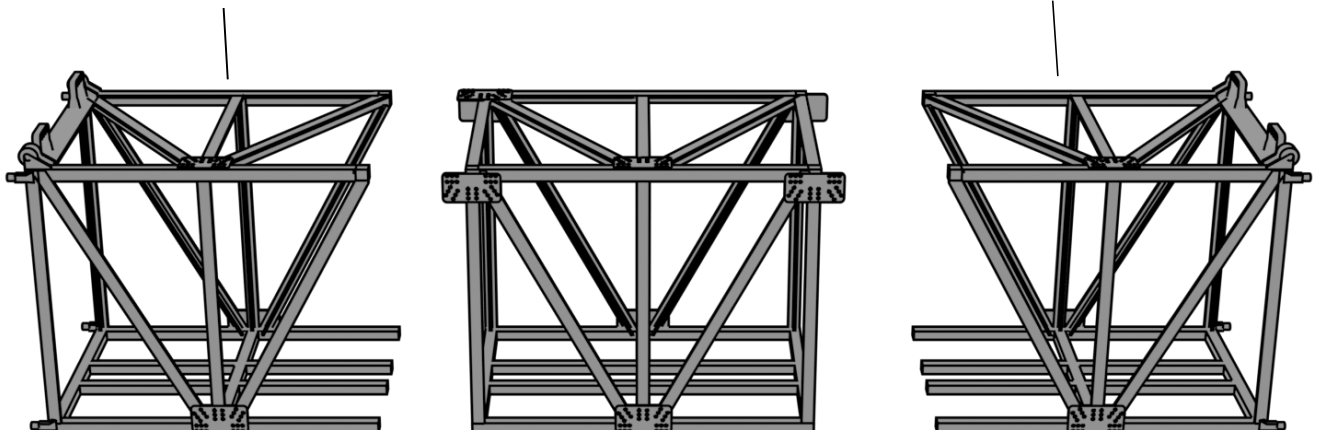

Single Track Lift Bridge

HO-Scale

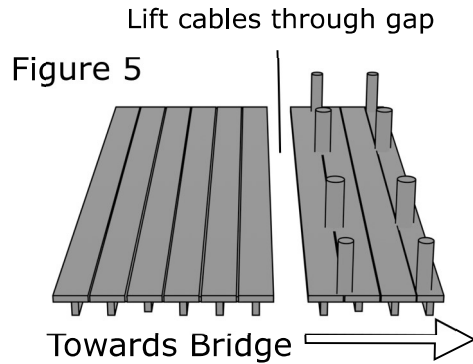

Note beam direction and angle

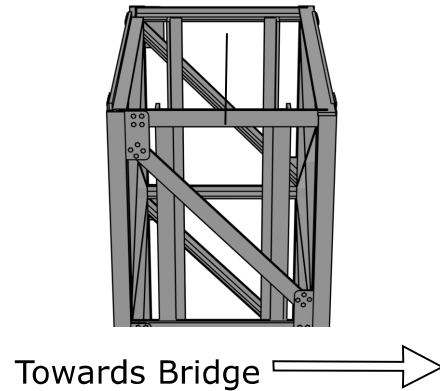

Connecting the counter-weight

1) After assembling the bridge and attaching the wires, pass the wires through the gap in the top of the tower (as shown in Figure 5).

2) Glue (if desired) the counterweight in position as shown in Figure A if the bridge is going to be in the down position, or as in Figure B if the bridge is going to be lifted.

3) Pass the wires through the counter-weight and pull them tight. Gluing them in place.

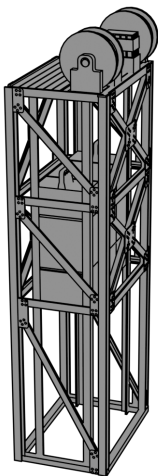

Figure A

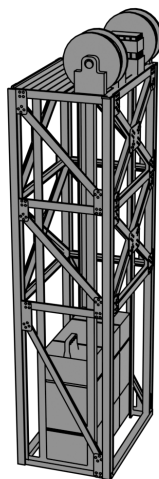

Figure B